

Arc Welding Robot

ARC10-1600

ARC10-1600 is a medium payloads robot.

Maxium payload 10 kg with maxium reach 1604 mm.

Highlights

Thanks to the large and hollow design, the cable can be routed in a hollow way, effectively improving the service life of the cable, and the posture change in a narrow space is more flexible;

High-rigid gearbox with strong impact resistance helps customers challenge various application scenarios;

Thanks to the high stiffness transmission design and advanced trajectory algorithm, the improved robot accuracy performance helps customers to face variety of application scenarios.

Applications

It can be used in Arc welding applications.

Industries

Suitable for metal parts, auto parts, steel structure and other industries.



EFORT

SPECIFICATIONS

Model	ARC10-1600	
Type	Articulated	
Controlled axes	6 Axes	
Max. payload on wrist	10 kg	
Repeatability	± 0.03 mm	
Robot weight	169 kg	
Reach	1604 mm	
Robot IP grade	IP54 / IP67 (Wrist)	
Cabinet IP grade	IP54	
Drive mode	AC servo drive	
Installation	Floor, Upside-down, Wall	
Installation enviroment	Ambient temperature	0~45 °C
	Ambient humidity	RH≤80% (No dew nor frost allowed)
	Vibration acceleration	4.9 m/s ² (< 0.5 G)

Allowable load moment at wrist	J4	22 N · m
	J5	22 N · m
	J6	9.8 N · m
Allowable load inertia at wrist	J4	0.65 kg · m ²
	J5	0.65 kg · m ²
	J6	0.17 kg · m ²
Maximum speed	J1	265°/sec
	J2	255°/sec
	J3	270°/sec
	J4	450°/sec
	J5	450°/sec
	J6	700°/sec
Motion range	J1	± 170°
	J2	+85°/-150°
	J3	+175°/-85°
	J4	± 190°
	J5	± 190° (The connect outside robot body.)
		± 140° (The connect inside robot body.)
	J6	± 450° (The connect outside robot body.)
		± 220° (The connect inside robot body.)

OPERATING SPACE

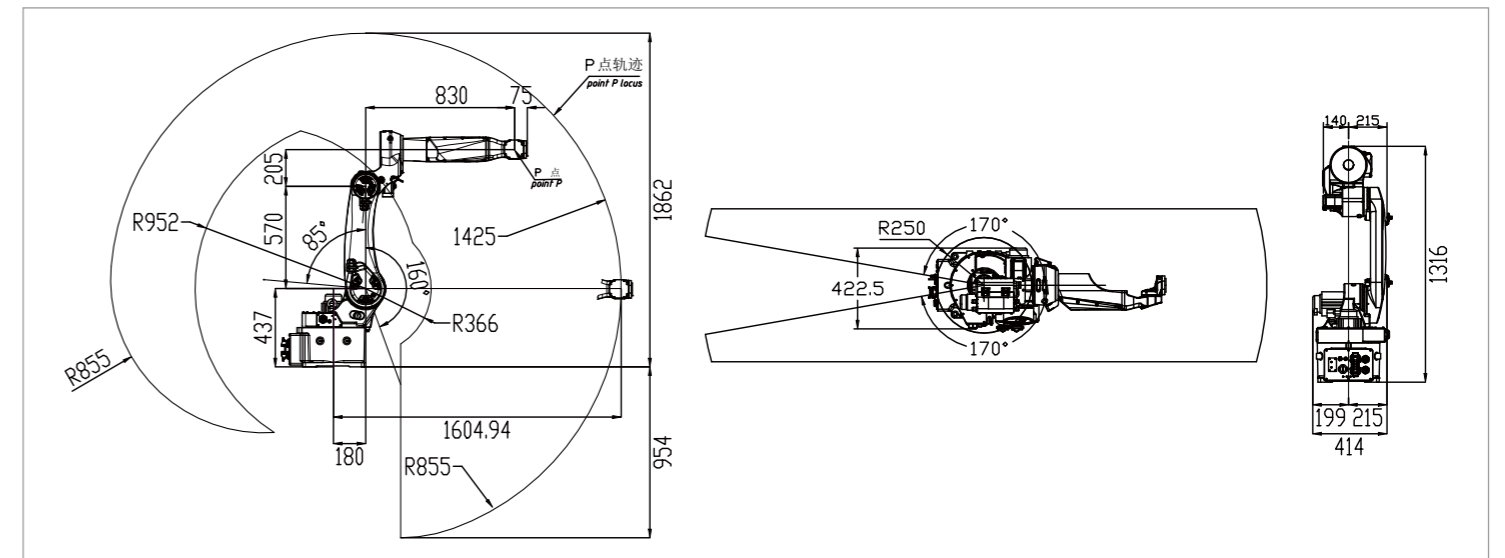

BASE MOUNTING SIZE

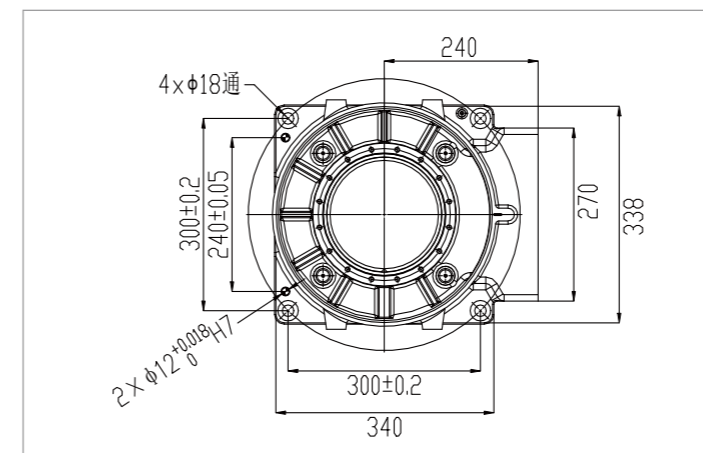

END FLANGE MOUNTING SIZE

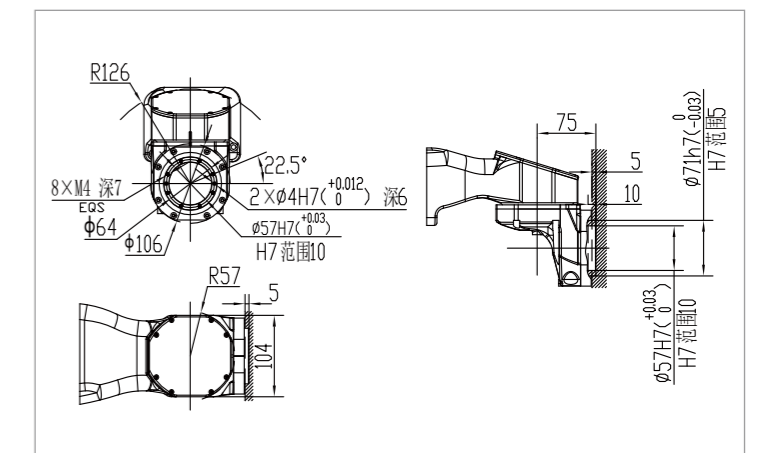

EFORT INTELLIGENT EQUIPMENT CO.,LTD.

PHONE: (00 86) 400-052-8877

ADDRESS: No.96 East Wanchun Road, China(Anhui) Pilot

Free Trade Zone Wuhu Area, Wuhu, Anhui Province, China

WWW.EFORT.COM.CN